



The Rutland 913

The Rutland 913 is designed for marine use on board coastal and ocean going yachts usually over 10m in length. This unit will generate enough power to serve both domestic and engine batteries on board and the RWS200 Controller is available for dual battery charging.

The Rutland 913 is a popular sight in marinas, thousands are in use worldwide, boat owners like it's clean, aerodynamic lines and its quiet and continuous operation. Without doubt this latest marine model accumulates more energy than any other comparable windcharger available, you'll always see a Rutland spinning in the lightest of breezes!

- Low wind speed start up of just 5 knots
- Generates 90w @ 19 knots, 24w @ 10 knots
- Delivers up to 250w
- One way only fit fine profile efficient aerofoil blades
- Three phase Rutland "unique" generator design
- Automatic thermostat protection in prolonged gales
- Modern, durable materials for reliability on the high seas
- No radiated interference - complies with EEC directive 89/336/EEC



Balance of System Components

- SR200 Regulator - Shunt type voltage regulator prevents battery overcharge
- RWS200 Controller - Incorporates the SR200 Regulator, charge ammeter, dual battery voltage LED's, two battery connection terminals and switch for charging one or two battery banks simultaneously, solar panel input (maximum 50w when used in combination with Rutland 913 windcharger). Housed in attractive white case with simple to follow graphics for installation.
- Marine Mounting Kit supplied in 2 sections of stainless steel plus deck fixing and fasteners.
- Other system components
Batteries, cable



UK / Europe / USA Office
Tel: +44 (0)8700 434040
Fax: +44 (0)8700 434045
E-mails - info@omniinstruments.co.uk
120-122 King Street ,Broughty Ferry,
Dundee, Scotland UK. DD5 1EW

Omni
Instruments
Measurement > Control > Data Acquisition
Web Site: www.omniinstruments.co.uk

Australia / Asia Pacific Office
Tel +61 (0)894 888 960
Fax +61 (0)894 888 965
info@omniinstruments.com.au
PO Box 105, Leederville
Western Australia, 6902



The Rutland 913

The Rutland 913 is Marlec's most popular battery charging wind turbine designed for use on board coastal and long distance cruising sailboats. It is also ideal for providing power for off- grid homes.

Below you will see the performance specification and the dimensions of the Rutland 913.

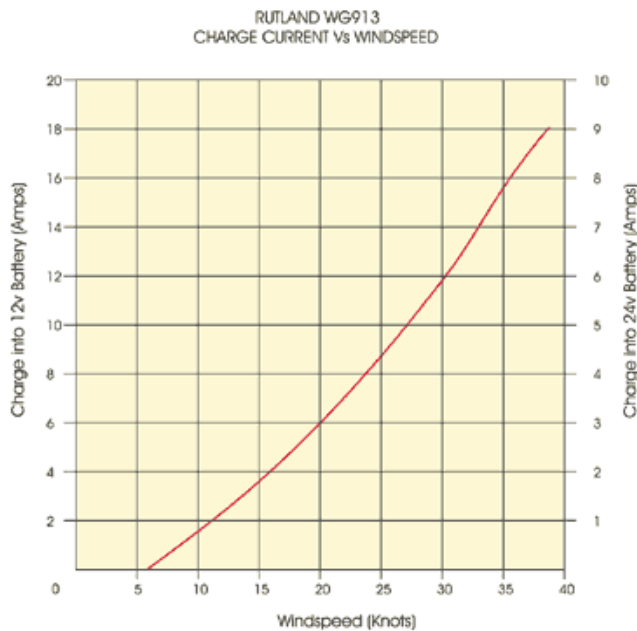

Dimensions

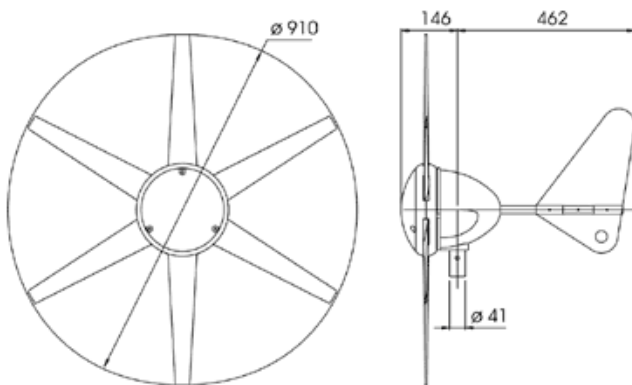

Shipping Specification (mm)

1 Carton 360 x 360 x 600
 Nett weight: 10.5kg
 Gross weight: 13kg

Technical Data

Wind turbine performance specifications are not created equal.....

That's because to date there are no firm international standards for how small wind turbines are "rated." Most grid connect wind turbines are given a power specification at 10m/s (meters per second), the equivalent of 22mph or 19Knots. They do of course produce more power in stronger wind speeds. Marlec chooses to rate our wind turbines at this same standard of 10m/s as we believe that as the industry matures a reasonable level such as this one will be established. Manufacturers rating points vary and consequently it is necessary to compare output graphs across a wide band of windspeeds rather than accept individual rating figures for wind turbines.

So how much power will a windcharger deliver?

The real measure of performance of wind turbines is "accumulated ampere hours" into a battery over a given period of time although this is a difficult measure for manufacturers to express since the users site for the windcharger will affect overall performance. Output graphs are usually an indication of instantaneous peak power at given wind speeds but in real conditions the wind is rarely constant, usually gusting up to 3 or 4 times the average.

Wind turbines can theoretically deliver 4 times the power in twice a given wind speed so calculating total power generated using average wind speeds is misleading.

As an example we will take 10 Knots as the average wind speed using a Rutland 913 Windcharger:

the Rutland 913 delivers 1.5A @ 10knots, then we could estimate a daily yield of 24hrs x 1.5A = 36Ampere hours. However at the extreme the wind may blow at 20 Knots for 12 hours and be calm for 12hours, showing 10Knots as the average so the potential power generated can be quite different, ie at 20 knots the Rutland 913 delivers 7A, therefore 12hrs x 7A = 84 Ampere hours.

The actual accumulated ampere hours in reality is somewhere in the middle demonstrating that average figures can be misleading. This also reinforces the benefit of wind generators that run freely in low winds maximising the available power of the more regular gentle breezes as well as the peaky gusts.

Consider the "fill factor"

The wind never blows constantly from one direction or at a steady wind speed, it blows in gusts. Most micro wind turbines are fitted with a free yawing mechanism and tail fin to direct the turbine into the wind. Where they differ is in the type of generator and aerofoil blades used which greatly affect their ability to adapt to the changing wind conditions. An unrivalled feature of all the Rutland designs is low wind speed performance. Our high inertia generators maintain momentum and speed between gusts of wind, continuing to generate power where more conventional designs slow down losing power and requiring a strong gust of wind to restart them. This means that overall a Rutland will generate more power into a battery bank in a day when compared to an equally sized or rated turbine and even in cases of generators of a higher "rated" capacity and turbine diameter! See the independent tests on our news pages and compare the turbine diameters to see that you don't always need a larger unit to generate the same or more power.

To sum it up:

- We keep it simple so it's reliable
- We use durable materials so it lasts
- We innovate to deliver the best efficiency possible

UK / Europe / USA Office
 Tel: +44 (0)8700 434040
 Fax: +44 (0)8700 434045
 E-mails - info@omniinstruments.co.uk
 120-122 King Street ,Broughty Ferry,
 Dundee, Scotland UK. DD5 1EW

Omni
Instruments
 Measurement > Control > Data Acquisition
 Web Site: www.omniinstruments.co.uk

Australia / Asia Pacific Office
 Tel +61 (0)894 888 960
 Fax +61 (0)894 888 965
info@omniinstruments.com.au
 PO Box 105, Leederville
 Western Australia, 6902