

LE-600

Technical Spec Sheet

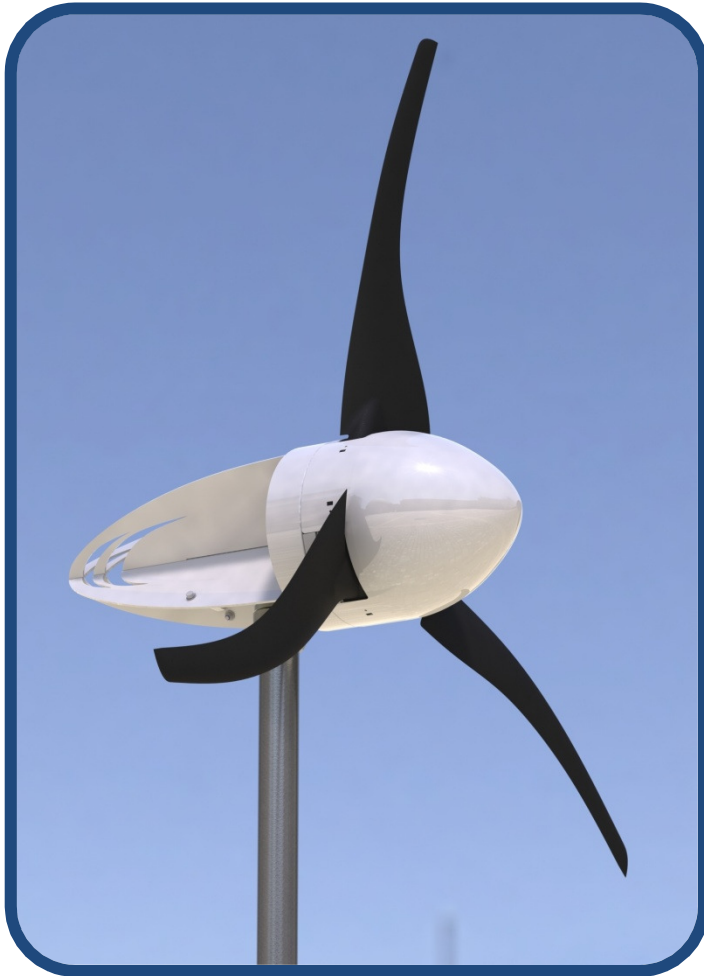

About the LE-600

Incredibly quiet, light and with fantastic power production the LE-600 wind generator is ideal for boats and yachts with the most demanding marine power needs.

The LE-600 is a unique downwind turbine which features a fully integrated axial flux 3-phase Permanent Magnet Generator (PMG) that uses the latest, most powerful neodymium iron boron magnet technology. This technology gives the LE-600 a very low cut-in speed which allows the turbine to generate power at low windspeeds, as well as delivering a higher output than the competition at higher windspeeds.

Designed and manufactured in the UK, the LE-600 uses our proprietary 'Whisper' blade technology. This means the turbine rotor system is incredibly quiet, UV resistant, extremely tough and designed to operate in perfect synergy with the axial flux Permanent Magnet Generator. The LE-600 has the ability to run at high output during high winds for prolonged periods. However, it is also equipped with a preset shut down system which automatically brakes the turbine should severe wind conditions occur for a long period of time. This automatic protection process makes the machine ideal for unmanned marine & other applications.

The 'X-wing' chassis design found on all small Leading Edge Turbines, including the LE-600, helps give the turbine excellent yawing responsiveness and structural integrity, with an all-up weight of only 19.5 kg. This makes installation of the turbine quick and easy, whilst minimising the forces exerted on the support structure. This is especially important in marine applications such as boats, where the turbine and support structure is moving. The 'X-wing' chassis houses fully integrated yaw slip-rings in the sealed underbelly of the chassis, so there can be 360 degrees of continuous yaw rotation without the output cables becoming twisted or tangled.

The turbine is manufactured from high grade aluminium alloy, stainless steel and glass reinforced composite polymers. All of the components are anodised or painted to a Category 5 protection level, meaning that the turbine will not corrode for up to 20 years in a salt water environment.

Twin LE-DL300 charge controllers prevent the turbine overcharging the battery bank by using a Pulse Width Modulation to divert excess power to 600W of dump load capacity. Simply put, this means that when the batteries are full any excess energy is diverted to a dump load (effectively a small heating

LE-600

Technical Spec Sheet



element). The advantage of this system is that the turbine can continue to spin under load, as opposed to being turned on and off frequently, which is noisy and not good for turbine longevity.

Features and Benefits of the LE-600 wind generator for boats

- High power output in all wind conditions
- Low RPM generator and unique swept turbine blades result in exceptionally quiet operation.
- Designed to run through severe weather conditions with automatic shutdown protection.
- All-up weight of just 19.5kg.
- Unique bearing and alternator configuration results in low friction, low bearing noise.
- 'X-wing' chassis design gives excellent yaw response in gusty conditions.
- Unique axial flux generator design, using powerful neodymium magnets, allows effortless start up in low winds.
- Fully marinised construction with category 5 protection level (15-20 years in a salt water environment).
- All bearings are lubricated and sealed for life
- Anti-vibration fixings and mounts used throughout.
- Integrated yaw-slip rings sealed from the elements
- Designed and manufactured in the UK
- Quieter and more efficient than any other turbine in its class.

LE-600

Technical Spec Sheet



LE-600

Daily Energy Production (est.)

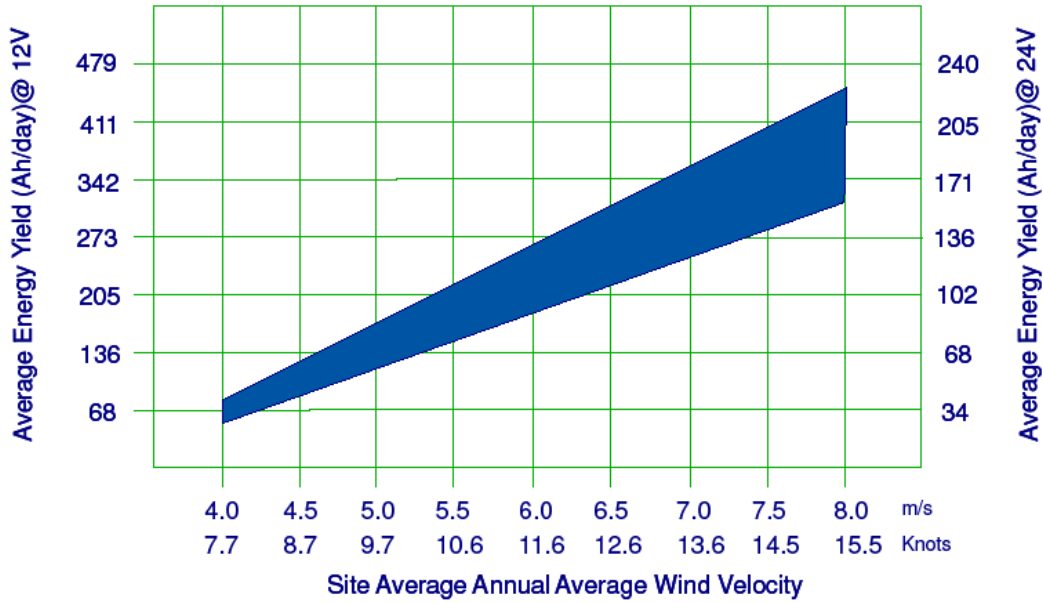

LE-600

Power Curve

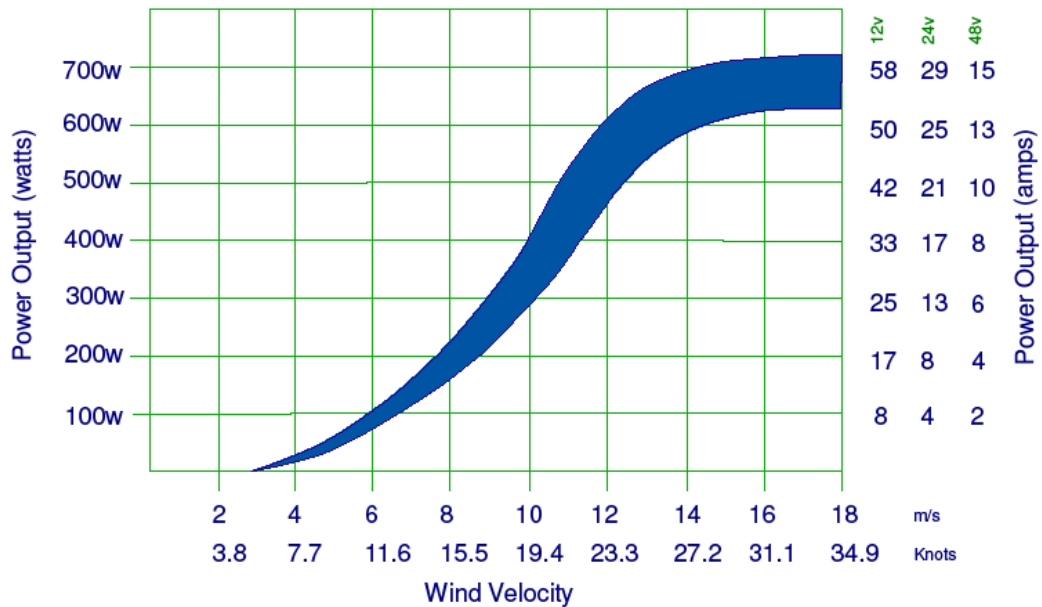

Contact us at: www.leturbines.com sales@leturbines.com 0845 652 0396

LE-600

Technical Spec Sheet

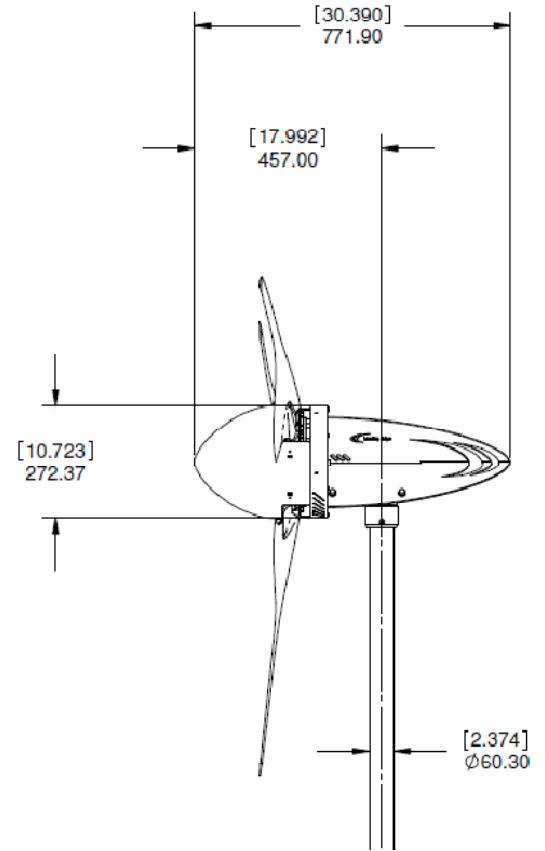
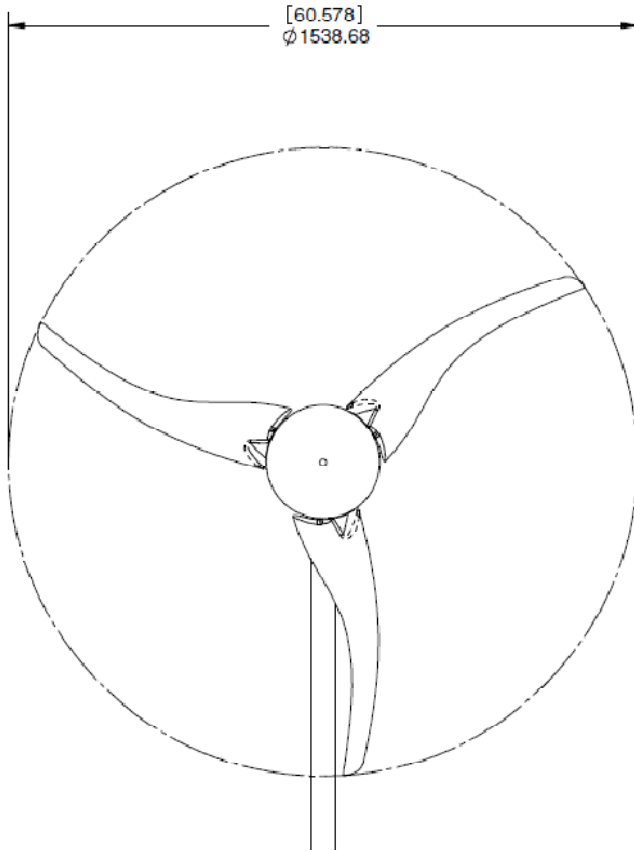

Specifications

Rotor Diameter:	1.54 metres
Rotor Type:	3-Blade downwind
Blade Material:	Glass Reinforced Nylon
Rated Wind Velocity:	7.20m/s (16.2mph)
Rated Output:	160 watts
Peak Output:	700 watts
Cut-in speed:	3m/s (6.7mph)

Estimated AEP:	250-1900kWh per year <i>Depending on site location & wind</i>
Weight:	19.5Kg
Generator Type:	3-Phase Brushless NIB magnet rotor out-runner PMA
Output voltage:	12, 24 or 48V
Lifetime & Servicing:	20 years Annual inspection recommended
Warranty	2 years